

GEM 50



LATEST GENERATION

GEM 50

[It]
DESCRIZIONE

Nastratrice per scatole a formato fisso.

La serie GEM caratterizzata da robustezza, semplicità e minima manutenzione a costi di gestione nella misura più ridotta.

[En]
DESCRIPTION

Uniform case sealer.

The GEM series featured by strength, simplicity and minimal maintenance at the lowest cost of ownership.

[Fr]
DESCRIPTION

Machine a fermer les caisses americaines monofomat.

La série GEM caractérisée par la robustesse, la simplicité et un entretien minimal pour des coûts de fonctionnement très réduits.

[De]
BESCHREIBUNG

Kartonschachtel-verschliessmaschine für gleichbleibende formate.

Die GEM-Serie zeichnet sich durch Robustheit, Einfachheit und minimale Wartung bei geringsten Betriebskosten aus.

[Es]
DESCRIPCIÓN

Precintadora para cajas de formato fijo.

La serie GEM se caracteriza por su robustez, simplicidad y mantenimiento mínimo con costes de funcionamiento más bajos.

DATI TECNICI:

TECHNICAL DATA:

DONNÉES TECHNIQUES:

TECHNISCHE DATEN:

FICHA TÉCNICA:

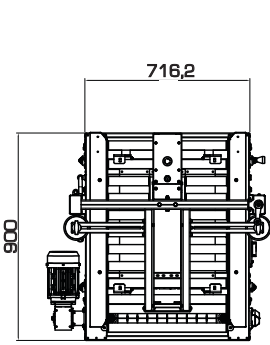

misure/measures/mesures/maßnahmen/medidas: mm

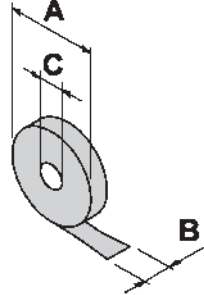
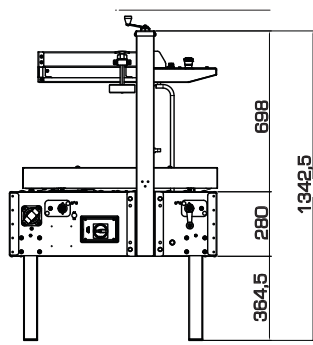

A	MAX 360 mm (14")
B	25÷75 mm (1"÷ 3")
C	76 mm (3")

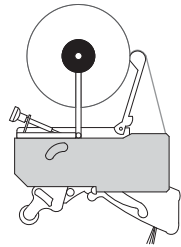

- Teste Nastranti:
- Taping Heads:
- Têtes de pose:
- Klebeköpfe:
- Cabezal de precinto:

T21-T21,5-T22-T23
T32-T33
TH22-TH23

- Gambe con piedino fisso
- Legs with fixed foot
- Pieds à base fixe
- Standbeine mit fixem Fuß
- Patas con pie fijo

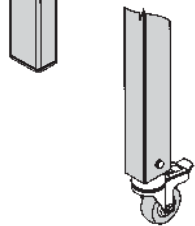

OPTIONAL:

- Gambe con ruote
- Legs with wheels
- Pieds à roulettes
- Standbeine mit Rädern
- Patas con ruedas

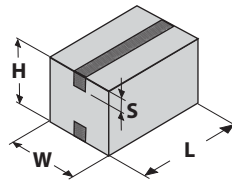

	MIN	MAX
L	150 mm	∞
W	100 mm	500 mm
H	100 mm	500 mm
S	25 mm	75 mm

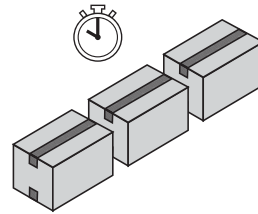

- Produzione media:
- Average production:
- Production moyenne: **1000 scatole/h**
- Durchschnittliche Produktion:
- Producción promedio:

- Velocità di trasferimento scatola:
- Box transfer speed:
- Vitesse de transfert de la boîte: **~22 mt/min**
- Transportgeschwindigkeit der Kartons:
- Velocidad de desplazamiento caja:



- Alimentazione:
- Power supply:
- Alimentation: **3 / ±**
- Speisung:
- Alimentación:

- Potenza installata:
- Installed power: **0,25 kW**
- Puissance installée:
- Eingerichtete Leistung:
- Potencia instalada:

- Protezione elettrica:
- Electrical protection:
- Protection électrique: **IP54**
- Stromschutz:
- Protección eléctrica:



- Temperatura di utilizzo:
- Temperature of use:
- Température d'utilisation:
- Betriebstemperatur:
- Temperatura de uso:

	MIN	MAX
°C	+5	+35
°F	+41	+95



- Peso:
- Weight: **90 Kg**
- Poids:
- Gewicht:
- Peso:

Distributed by

COMARME

COMARME S.r.l. a socio unico

sede operativa (factory)
Quartiere Mirabella snc, 20081 Abbiategrasso (MI) - ITALY
Tel. +39 02 9422002 - Fax +39 02 9422096

e-mail: info@comarmesrl.com - website: www.comarmesrl.com