

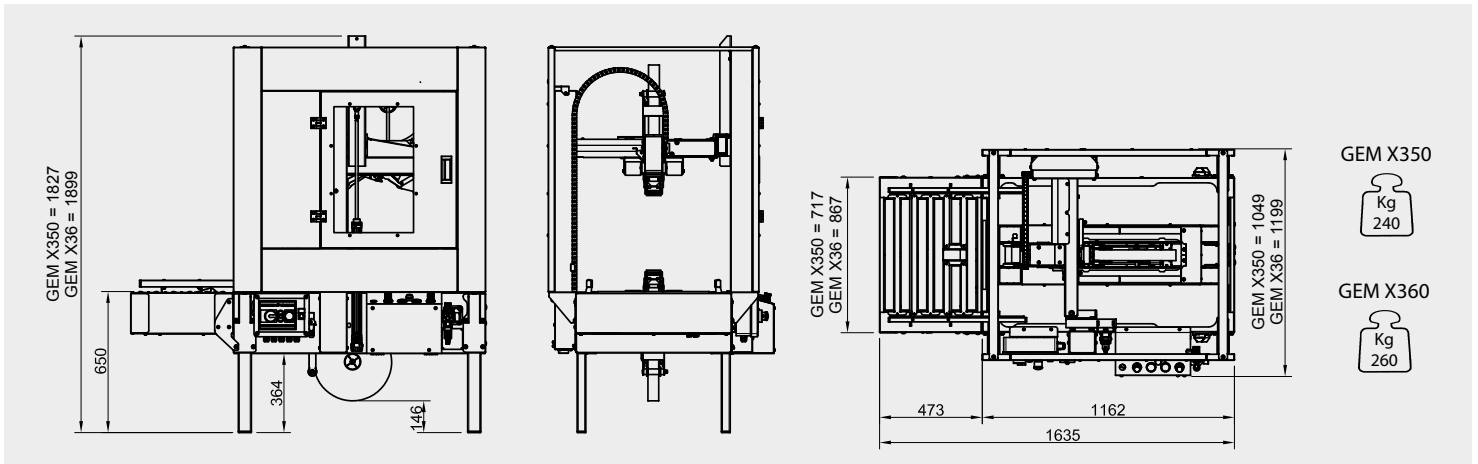

GEM X350 / X360

- NASTRATRICE SEMI-AUTOMATICA AUTODIMENSIONANTE
- SEMIAUTOMATIC SELF-DIMENSIONING TAPING MACHINE
- FERMEUSE AUTORÉGLABLE POUR CARTONS MULTI-FORMAT
- HALBAUTOMATISCHE VERKLEBEMASCHINE FÜR KARTONS MIT WECHSELNDEN FORMATEN
- PRECINTADORA SEMIAUTOMÁTICA CON DIMENSIONAMIENTO AUTOMÁTICO DE CAJAS DE FORMATO VARIABLE



GEM X350

- Teste Nastranti: configurazione standard · Taping heads: standard configuration
- Têtes de pose: configuration standard · Klebeköpfe: standardkonfiguration
- Cabezal de precinto: configuración estándar
T22 - 23 (standard)
T21 - T21,5 (optional)

GEM X360

- Teste Nastranti: configurazione standard · Taping heads: standard configuration
- Têtes de pose: configuration standard · Klebeköpfe: standardkonfiguration
- Cabezal de precinto: configuración estándar
T32 - T33 (standard)
T21-T21,5-T22-T23 con - avec - with - mit - con Kit adaptor 2 (optional)

- Alimentazione pneumatica
- Pneumatic power supply
- Alimentation pneumatique
- Druckluftspeisung
- Alimentación neumática

- Consumo aria per ciclo scatola
- Air consumption cycle box
- Consommation d'air par cycle boîtes
- Luftverbrauch pro Kartonzyklus
- Consumo de aire por ciclo caja

6 bar

7,5 nl

GEM X350



GEM X360

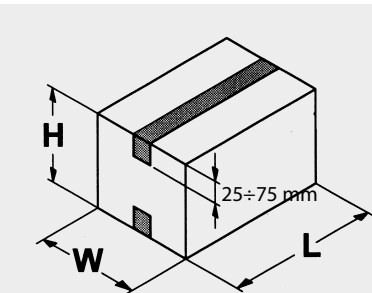

GEM X350

	MIN	MAX
L	150 mm	∞
W	130 mm	500 mm
H	100 mm	500 mm

GEM X360

	MIN	MAX
L	150 mm	∞
W	155 mm	650 mm
H	100 mm	650 mm

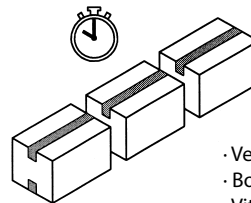

- Produzione media: 600 scatole/ora
- Production moyenne: 600 boîtes/heure
- Producción promedio: 600 cajas/hora
- Average production: 600 boxes/hour
- Durchschnittliche Produktion: 600 Kartons/Std

- Velocità di trasferimento scatola: ~22 mt/min
- Box transfer speed: ~22 mt/min
- Vitesse de transfert de la boîte: ~22 mt/min
- Transportgeschwindigkeit der Kartons: ~22 mt/min
- Velocidad de desplazamiento caja: ~22 mt/min



- Alimentazione: standard - 3 PH + PE
- Power supply: standard - 3 PH + PE
- Alimentation: standard - 3 PH + PE
- Speisung: standard - 3 PH + PE
- Alimentación: standard - 3 PH + PE

- Potenza installata: 0,25 kW
- Installed power: 0,25 kW
- Puissance installée: 0,25 kW
- Eingerichtete Leistung: 0,25 kW
- Potencia instalada: 0,25 kW
- Protezione elettrica: IP54
- Electrical protection: IP54
- Protection électrique: IP54
- Stromschutz: IP54
- Protección eléctrica: IP54

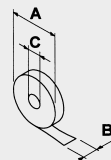

GEM X350	
A	MAX 360 mm
B	25 ÷ 50 mm
C	76 mm

GEM X360	
A	MAX 360mm
B	25 ÷ 75 mm
C	76 mm

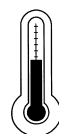

MAX
+35°C/95°F

MIN
+5°C/41°F

- Temperatura di utilizzo:
- Temperature of use:
- Température d'utilisation:
- Betriebstemperatur:
- Temperatura de uso:

ITALY ACCESSORI:

- Rulliere in ingresso / uscita
- Kit start/stop
- Kit RFN
- Gambe con ruote
- Vano chiusura inferiore
- Kit portabobine cablato con sensori
- Quadro elettrico con PLC Siemens e HMI 4"

UK ACCESSORIES:

- Roller conveyors for box entrance and exit
- Belts switching off kit
- Legs with casters
- RFC Kit
- Lower closure cover
- Wired roll holder kit with sensors
- Electrical cabinet with Siemens PLC & digital HMI

FRA ACCESSORIES:

- Convoyeurs
- Kit arrêt courroies
- Pieds à roulettes
- Kit RFN (rupture/fin de ruban)
- Couvercle de fermeture inférieure
- Kit porte-bobine câblé avec senseurs
- Panneau de commandes automate Siemens

GER ZUBEHÖR:

- Rollenbahnen für Ein- und Ausgang der Kartons
- Fotozellen- Kit für automatisches Abschalten
- Standbeine mit Rädern
- Kit mit schwenkbaren Rädern mit Bremse
- Klebebandkontrolle
- Unterer Verschlussdeckel
- Kit verkabelter Spulenträger mit Sensoren
- Steuerung Siemens und Digitales Bedienfeld Kite

ESP ACCESORIOS:

- Transportadores de rodillos
- Kit con fotocélula para el apagado automático
- Pieds à roulettes
- Kit de control de la aplicación de la cinta (RFN)
- Tapa inferior
- Kit de portabobinas cableado con sensores
- Quadro eléctrico con PLC Siemens y panel de control digital

Distributed by



COMARME S.r.l. a socio unico
sede operativa (factory)

Quartiere Mirabella snc, 20081 Abbiategrasso (MI) - ITALY
Tel. +39 02 9422002 - Fax +39 02 9422096

e-mail: info@comarmesrl.com - website: www.comarmesrl.com