

HM F470T/B - HM F470S T/B - HM F520T/B

- NASTRATRICE AUTOMATICA A DIMENSIONAMENTO MANUALE CON CHIUDIFALDE ED APPLICAZIONE DI COLLA HOT MELT
- AUTOMATIC CARTON SEALER BY HOT MELT WITH MANUAL DIMENSIONING AND FLAP CLOSER
- FERMEUSE AUTOMATIQUE À DIMENSIONNEMENT MANUEL AVEC DISPOSITIF DE FERMETURE DE RABATS AVEC SYSTEME D'APPLICATION HOT MELT
- AUTOMATISCHE VERKLEBEMASCHINE MIT MANUELLER EINSTELLUNG UND DECKELZUFALTVORRICHTUNG MIT HEISS SCHMELZKLEBER.
- PRECINTADORA AUTOMÁTICA CON DIMENSIONAMIENTO MANUAL Y CON DISPOSITIVO DE CERRAR SOLAPAS EN HOT MELT

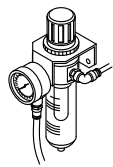
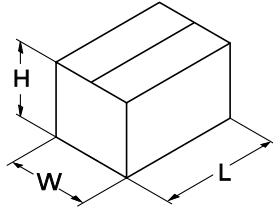
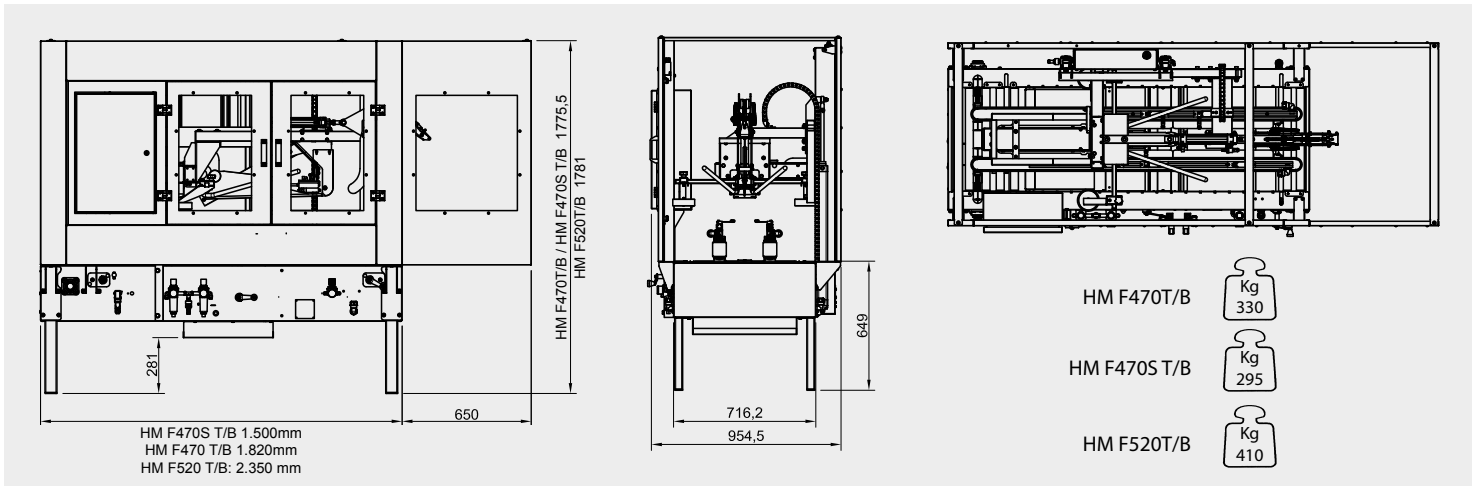

- Alimentazione pneumatica
 - Pneumatic power supply
 - Alimentation pneumatique
 - Druckluftspeisung
 - Alimentación neumática
 - Consumo aria per ciclo scatola
 - Air consumption cycle box
 - Consommation d'air par cycle boîtes
 - Luftverbrauch pro Kartonzyklus
 - Consumo de aire por ciclo caja
- 6 bar o 6x10⁵ Pa ~13 nl /6 bar

HM F470 T / HM F470S T

	MIN	MAX
L	200 mm	400 mm
W	150/200** mm	420 mm
H	100 mm	670 mm

HM F470 TB / HM F470S TB

	MIN	MAX
L	200 mm	400 mm
W	150/200** mm	420 mm
H	200 mm	550 mm

HM F520 T

	MIN	MAX
L	200 mm	600 mm
W	150/200** mm	420 mm
H	100 mm	670 mm

HM F520 TB

	MIN	MAX
L	200 mm	600 mm
W	150/200** mm	420 mm
H	150 mm	670 mm



- Alimentazione: Standard 3 PH + N + PE
- Power supply: Standard 3 PH + N + PE
- Alimentation: Standard 3 PH + N + PE
- Speisung: Standard 3 PH + N + PE
- Alimentación: Standard 3 PH + N + PE

- Potenza installata: 3 kW
- Installed power: 3 kW
- Puissance installée: 3 kW
- Eingerichtete Leistung: 3 kW
- Potencia instalada: 3 kW
- Protezione elettrica: IP54
- Electrical protection: IP54
- Protection électrique: IP54
- Stromschutz: IP54
- Protección eléctrica: IP54

- 🇮🇹 ** 150mm con 2 ugelli // 200mm con 4 ugelli
- 🇬🇧 ** 150mm with 2 nozzles // 200mm with 4 nozzles
- 🇫🇷 ** 150mm avec 2 tuyères // 200mm avec 4 tuyères
- 🇩🇪 ** 150mm mit 2 Düsen-Spritzkopf // 200mm mit 4 Düsen-Spritzkopf
- 🇪🇸 ** 150mm con 2 boquillas // 200mm avec 4 boquillas

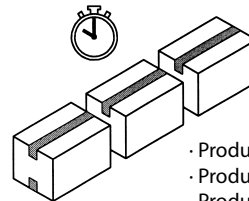

- Produzione media: 1000 ÷ 1100 scatole/ora
- Production moyenne: 1000 ÷ 1100 boîtes/heure
- Producción promedio: 1000 ÷ 1100 cajas/hora
- Average production: 1000 ÷ 1100 boxes/hour
- Durchschnittliche Produktion: 1000 ÷ 1100 Kartons/Std



- Temperatura di utilizzo: MAX
- Temperature of use: +35°C/95°F
- Température d'utilisation: MIN
- Betriebstemperatur: +5°C/41°F
- Temperatura de uso: MIN

- Velocità di trasferimento scatola: ~21mt/min
- Vitesse de transfert de la boîte: ~21mt/min
- Velocidad de desplazamiento caja: ~21mt/min
- Box transfer speed: ~21m/min
- Transportgeschwindigkeit der Kartons: ~21m/min

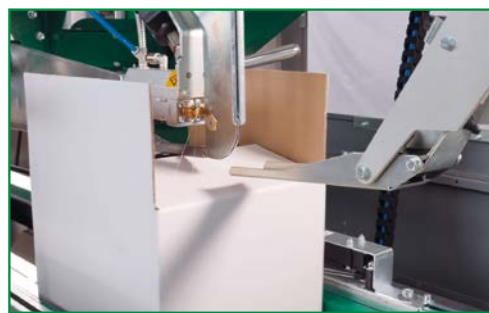

Distributed by



COMARME S.r.l. a socio unico
 sede operativa (factory)
 Quartiere Mirabella snc, 20081 Abbiategrasso (MI) - ITALY
 Tel. +39 02 9422002 - Fax +39 02 9422096
 e-mail: info@comarmesrl.com - website: www.comarmesrl.com